

A tangible sculpture

The **Hammock Chair** is a remarkable sculpture made to offer a tangible relaxing experience. The beautiful curves balance with the sturdy moulded wood construction and the flag line pattern with an excessive elegance elevates this bold design into one of Wegner's truly unique creations.

Based on the idea of stretching out a flexible surface of flag line strings in a wooden frame, Wegner has created the resemblance of a hammock in a reclining chair. Within this design concept Wegner introduced the simple metal clips that allow the characteristic pattern in the string work, which was a feature of the early 1960's sketches of the **Circle Chair**.



CONTEXT

ENQUIRIES
info@contextgallery.com
Tel. 404. 477. 3301
Tel. 800. 886.0867
contextgallery.com

Hammock Chair

Design: Hans J. Wegner, 1967

pp135

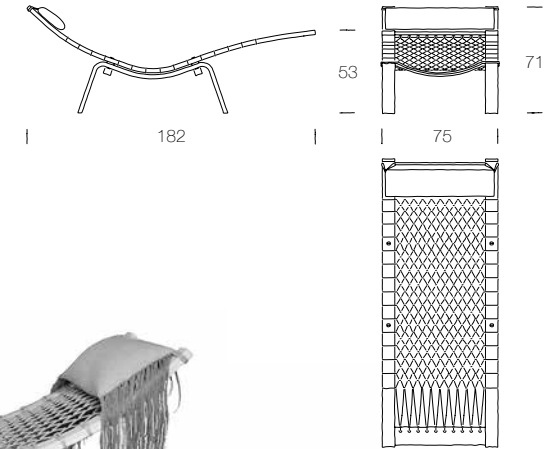

pp135 comes in oak or ash. Both woods are available soap treated or oil treated.

pp135 comes with an upholstered pillow and neckrest in fabric.

The flag halyard is available in nature or black. Flag line is made from jute and has a high tensile nylon core for optimal strength covered by a protective sleeve of woven jute. In order to optimise rigidity the flag line is stretched before it is applied to the chair. The clips connecting the flag halyard come in stainless steel, brass or black.