

Flag Halyard Chair

Design: Hans J. Wegner, 1950

pp225

ENQUIRIES
info@contextgallery.com

Tel. 404.477.3301
Tel. 800.886.0867

contextgallery.com



A day at the beach

With a frame made of solid stainless steel, 240 metres of specially developed flag line forming the seat and back and a longhaired sheepskin softening the industrial sharpness of the steel, this chair constitutes ultimate and luxurious relaxation!

Although the appearance of the **Flag Halyard Chair** seems rather futuristic, the basic idea was conceived on a hot summer afternoon in rather trivial circumstances. While the kids were playing in the shallow waters along the beach, Wegner was digging himself into the sand building a comfortable chair to enjoy the holidays.

Back in the summerhouse Wegner made the first sketches using the seating angles that he had conceived on the beach.

Despite having obvious preferences for wood, Wegner shows his bold and courageous appetite for creating. With the **Flag Halyard Chair** he pays a tribute to the early modernists such as Le Corbusier, Mies van der Rohe, and Marcel Breuer, and proves that he mastered stainless steel with the same conclusive elegance as he mastered wood.



Flag Halyard Chair

Design: Hans J. Wegner, 1950

pp225

pp225 comes with a unique sheepskin for further comfort. All sheepskin are produced in Iceland, and are a bi-product of food production. All sheep lived in the open fields and their hides has been processed without the use of chrome.

pp225 is available in natural or black flag line. Flag line is made from jute and has a high tensile nylon core for optimal strength covered by a protective sleeve of woven jute. In order to optimise rigidity the flag line is stretched before it is applied to the chair.

It comes with a leather or fabric upholstered neck cushion held by brittle leather or jute straps.

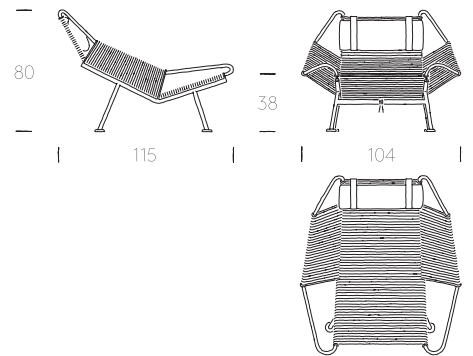

pp møbler

Vestvej 45
3450 Allerød
Denmark

info@pp.dk
www.pp.dk

